

Flaming Star Pack Systems

Instruction Manual

V 2.2



Congratulations! You have purchased the finest semi-rigid llama pack system available!

Flaming Star packs began in 1992 with a mission to make a comfortable, functional, durable pack. The founder, Sid Lilienthal, worked diligently to design, manufacture, and make available a pack that would, first and foremost, be safe and comfortable for the llama, and be built in a way to meet the specific structural needs of llamas, i.e. designing and building a saddle that did not put any pressure on a llama's spine. Llamas differ from equines in that prolonged, direct pressure on the vertebrae can cause injury or even paralysis. Flaming Star saddles are built to evenly distribute the weight on either side of the spine along the upper portion of the rib cage. A two-cinch system is employed to keep the saddle firmly in place, and to avoid shifting that may lead to soreness.

Through the years, Sid has used the suggestions from pack owners to improve the system and made several models to meet specialized needs. In 2005, Barb Brady purchased Flaming Star from Sid and continues to offer quality craftsmanship and customized products.

Disclaimer

Although every effort has been made to insure the information within this manual is accurate, Llama Hardware and its sales representatives cannot be held responsible for any injury or property damage that occurs in the course of using this equipment.

Please read this manual thoroughly before saddling your llama. If you have any questions, please contact the manufacturer directly at 1-509-238-2998, or info@llamahardware.com.

Reference Material

Here are three great reference books to learn more about packing with llamas.

Evaluating a Llama Pack for Comfort and Function, by Gwen Ingram
Llama Packing with Rudy, by Rudy Stauffer
Packing with Llamas, by Stanlynn Daugherty

Rudy also gives packing clinics twice a year at his home in Placerville, CA and can be contacted at 530-642-1120 or ruedillama@directcon.net

Recommended Care: Panniers can be turned inside out and washed with mild detergent in cold water on the gentle cycle. Do not use bleach. Air dry thoroughly before storing. Do not allow contact with alcohol-based products. Apply spray-on water repellent as needed to maintain water repellent characteristics and to help prevent stains. Store in plastic tubs or hang on wall to prevent damage by rodents.

© 2007 Llama Hardware. All rights reserved. No portion of this manual may be reproduced without written permission.

Parts of the Flaming Star System

Your full-size Flaming Star Packs include the following:

For Wrangler, Deluxe, Standard, and Master models, your system includes a saddle with two cinches, two panniers, chest plate, top load straps, and a belly strap.

Saddle

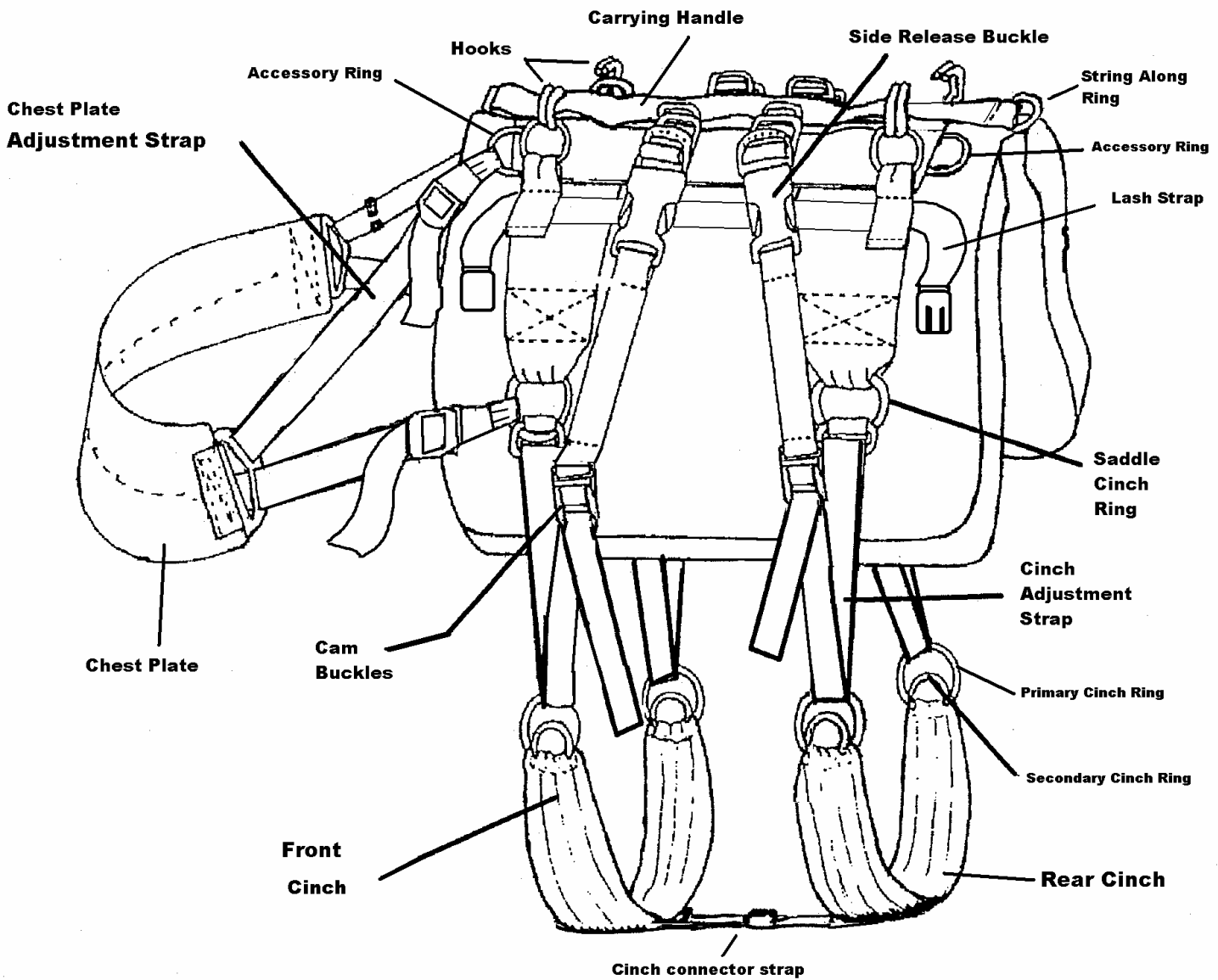

Standard colors are: lash straps – gray, top load straps – yellow, belly strap – tan. The colors on your system may vary.

Panniers

Deluxe Model

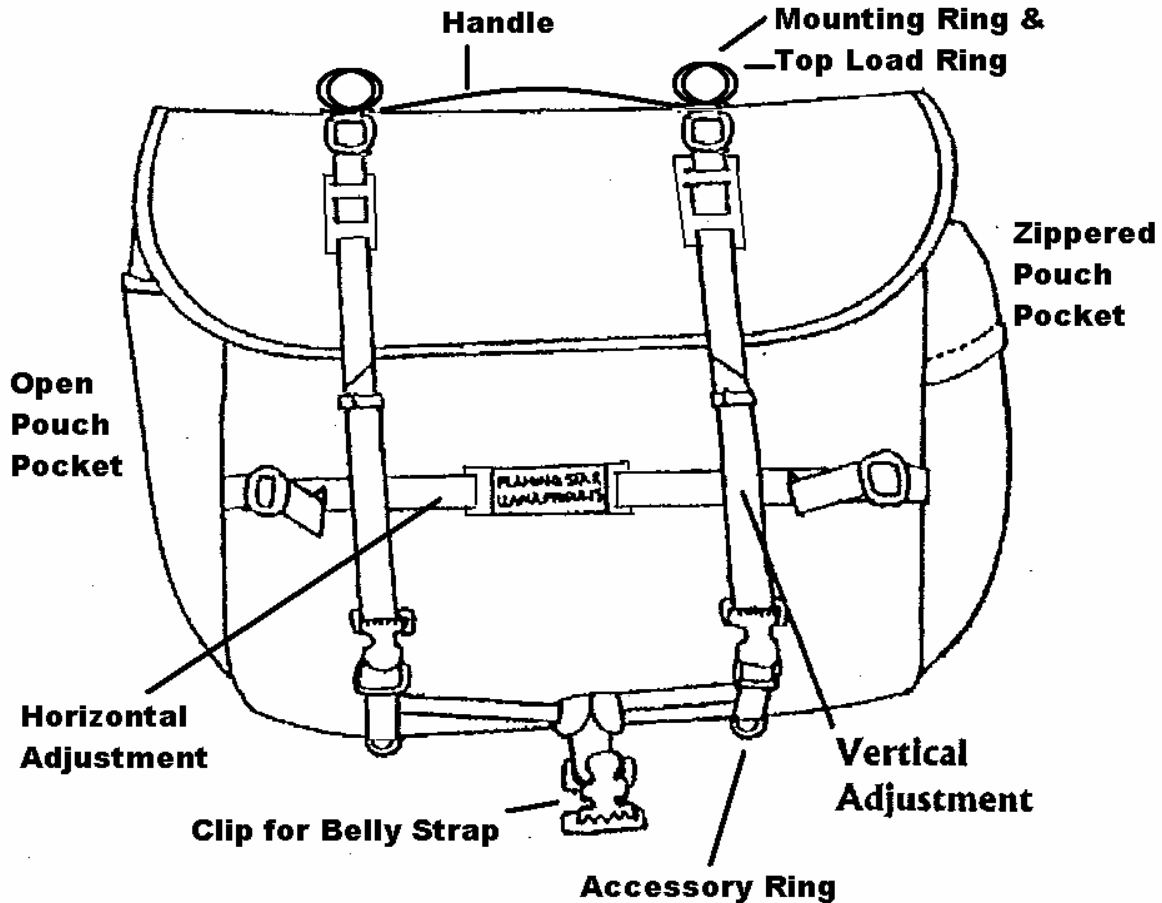

Above is the **Deluxe** pannier with a zippered pouch pocket and an open pouch pocket. The **Standard** has two open pouch pockets. The **Wrangler** model has two open flat-bottom pockets, and two zippered flat bottom pockets.

Weather guard

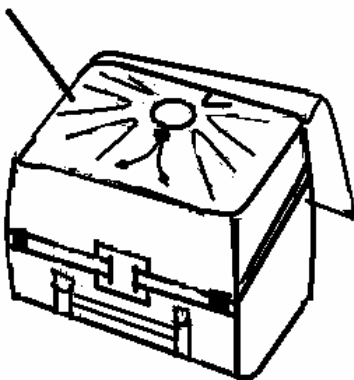

The weatherguard keeps your gear securely inside the pannier, and it really comes in handy if you are overloading the pannier with bulky items. It also protects the contents from dust.

The weatherguard itself is waterproof, but, depending on how it's closed, it may or may not keep the contents of your pack dry. For extra protection in bad weather, please use a rainfly.

Wrangler Model

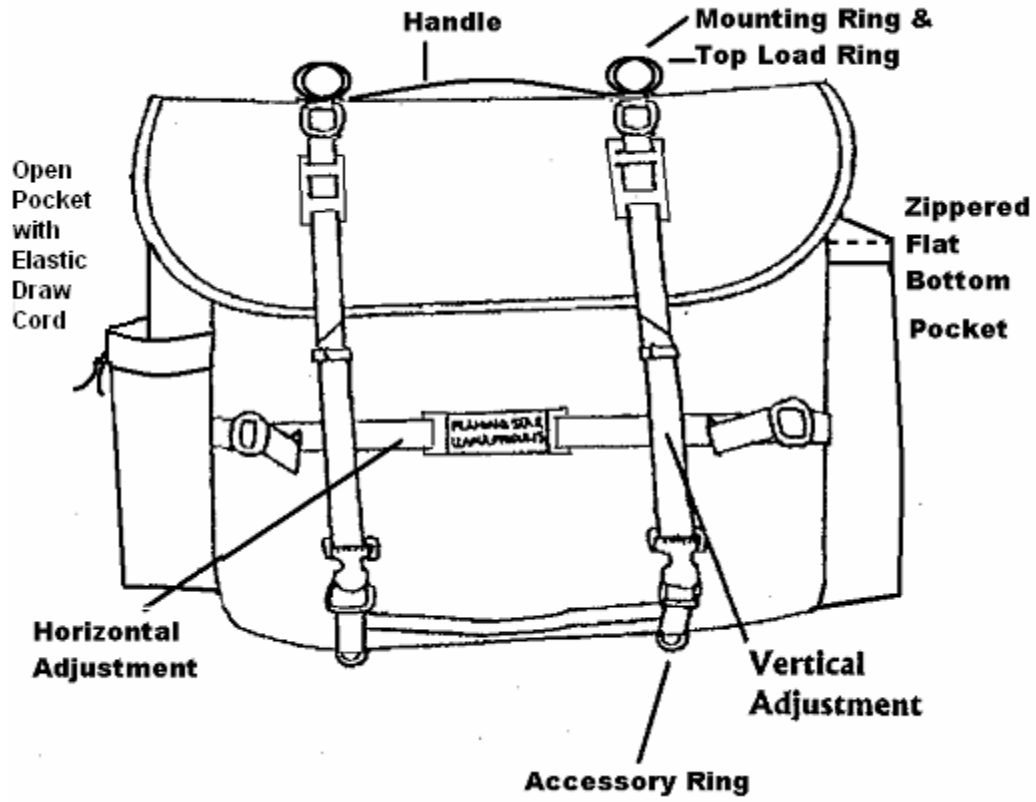

Master Model

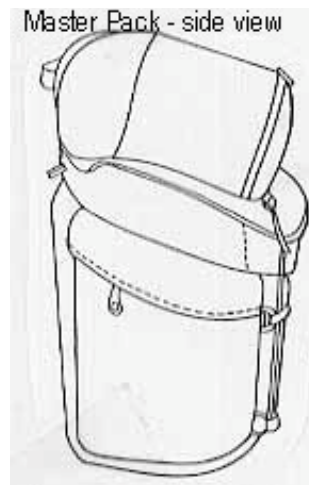

Saddling Your Llama

The **saddle** is designed to be placed behind the withers and put on tightly. Place the leading edge of the front cinch along the edge of the hairless area of the armpit. Do not place the cinch in the armpit as it can cause sores. The front cinch should be as tight as possible. The back edge of the rear cinch should be placed in front of a male llama's penal sheath, or in front of a female llama's udder. Angle the rear cinch adjustment strap to come off the back corner of the saddle to take advantage of the natural slope of the abdomen. The rear cinch should be very snug. If the saddle moves forward onto the withers, the rear cinch is not tight enough and the saddle should be remounted to prevent the front cinch from entering the armpit area.

The **cinches** provide comfort for the llama and stability for the saddle. The cinch rings should be at an equal distance from the saddle on each side of the llama. The front cinch rings should be located behind and above the armpit of the llama. The rear cinch ring should be exposed to your sight and fairly close to the saddle. If the cinch ring touches the saddle and the saddle is not tight, you will need to get shorter cinches. If you have cinches of two different lengths, the shorter cinch will usually be placed in the rear position. The cinch connector strap is designed to keep the rear cinch from sliding too far back. It can be adjusted after the two cinches are tightened.

The **chest plate** is used to keep trailing llamas from pulling the saddle too far back on the leading llama. It is also useful on very steep uphill trails or if the llama has to do some lunging. Place the chest plate according to the diagram below as adjust the straps so the llama can still graze in comfort. It should be loose enough to slip your hand between it and the llama.

Use the previous diagrams to make yourself familiar with the parts of the saddle and panniers. Put the saddle in front on you as shown in the drawing (chest plate on the left).

1. Disconnect the two snaps on the chest plate from the left side of the saddle.
2. Pinch the two side release buckles on the left side of the saddle and release the cinches. Adjust the cinch connector strap to full length.
3. Press the cam buckle to allow a lot of slack in the cinch adjustment strap. This makes it easier to fit to the llama on the first try.
4. Hang the left cinch ring from the hooks on the right side of the saddle to keep them from dangling. Drape the chest plate over the saddle for the same reason.
5. Place the front edge of the saddle at the rear edge of the llama's wither. See below.

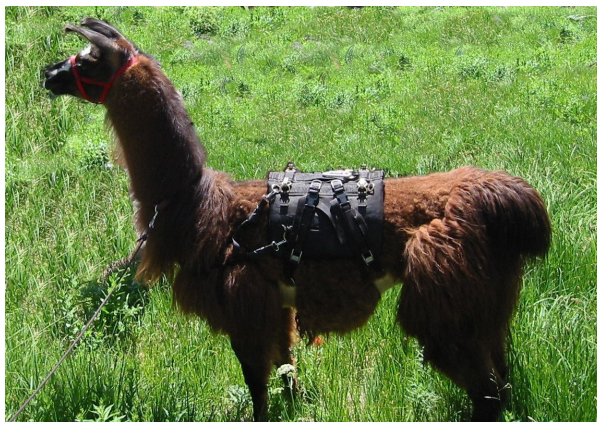
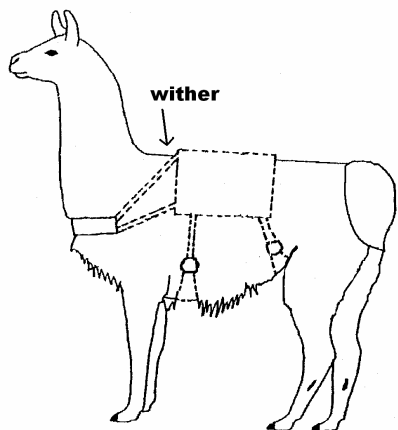

6. From the right side of the llama, remove the cinch rings from the right saddle hooks and let dangle. Ensure that all straps are in position and flat with no twists.
7. From the left side of the llama, reach under and grab the front cinch. You may need someone to hand it to you from the other side if your llama is uncooperative. Run the side release/cam buckle strap through the larger cinch ring and snap the side release into place. If you have given the cinch adjustment strap plenty of slack, this should be easy to do.
8. With your left hand behind the cinch ring, tighten the cinch by using a ratcheting motion with your right hand. See below. For first-time fitting, both sides may need to be adjusted to keep the cinch centered. After the front cinch has been tightened, repeat the process with the rear cinch. Keep in mind that the rear cinch is placed directly in front of the penal sheath on males and in front of the udder on females. This placement is critical in keeping the pack from sliding forward. If placed in the proper position and cinched tightly, use of a rump strap or breeching is not necessary.

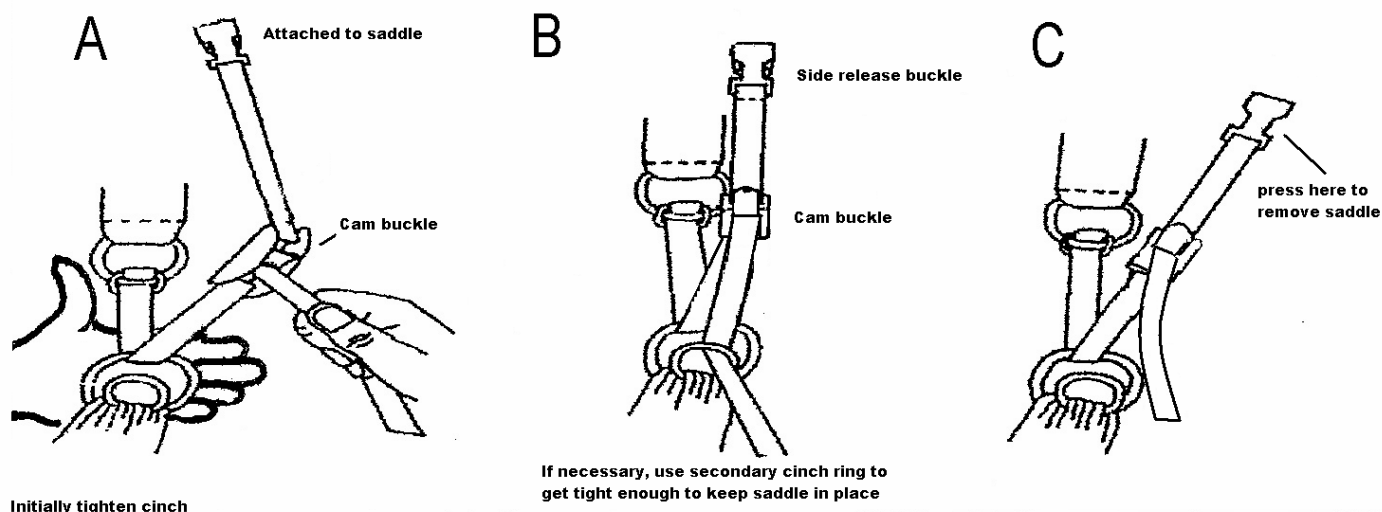

A. With the end of the cinch adjustment strap in hand, raise your hand away from the saddle. With steady tension on the strap, lower your hand and take up slack through the cam buckle. Do this in a smooth ratcheting motion. Keep your free hand behind the cinch ring to keep the fiber from being pulled. **Pulling fiber into the cinch ring is the main cause of llamas being hard to saddle, so please take care to avoid it at all costs.** At this point, the saddle may be tight enough. If you feel it is not, and you have the secondary cinch ring on your cinch, see paragraph B.

B. Place the end of the cinch adjustment strap through the secondary cinch ring (see illustration). Tighten the cinch some more by pulling and lifting. Usually, you can tighten the cinch adjustment strap another inch or so. The cinch will be tight at this point, and you may need to pull straight away from the llama.

C. To remove the saddle, depress the cam buckles (on your working side only) and give enough slack to be ready for next time. The cam buckles are used to loosen and tighten only and are generally not disengaged from the cinch adjustment strap.

Squeeze the side release buckles and release the cinch adjustment straps from the cinches.

How tight should the cinches be?

Properly placed, cinched, and loaded, the saddle is very stable and will stay in place during pack trips no matter what the terrain. If this is your first Flaming Star saddle, you may be surprised at how tight the cinches must be. Remember, this is a soft saddle and more compression occurs as the saddle conforms to the back of the llama than it would if a rigid saw buck type saddle was used. Additionally, the more fiber your llama has under the saddle, the more compression will occur. Llamas will also inflate themselves (like their equine counterparts) during saddling. Here is a good regimen to adopt when saddling:

First, be certain that there is no debris in the fiber or sores on the llama that will cause discomfort by placing a saddle or cinches on top of it. It is a good idea after brushing, to rub the belly area with your hand to ensure there are no sticks or burrs attached to the fiber. Saddle your llama using the above instructions and diagrams. Connect the front cinch and tighten enough so the saddle doesn't move before connecting the rear cinch and chest plate. This is a safety issue in case the llama acts up, he won't end up with a saddle hanging around his neck or under his belly. The cinches and chest plate are removed in the reverse order that they were connected.

Adjust the cinch adjustment straps on both sides of the llama so that the cinches evenly straddle the belly area. Tighten the cinches so that you can barely get a finger or two under the edge of the cinch. Now, tighten the cinch connect strap to keep the rear cinch from moving any farther towards the back of the llama.

Load your panniers and weigh them. They should be within 2 lbs of each other to prevent the saddle from listing to one side. If your saddle gets off center and the load is balanced, your front cinch is likely too loose. If the load rides up on the withers, your rear cinch is too loose.

Before you load the panniers onto the saddle, check the cinches and tighten if necessary. If your llama has expanded his belly prior to saddling, your cinches may not be tight enough. Once the panniers are loaded and secured with a belly strap or cinch-to-pannier straps, check the cinches again, as compression of the fiber and saddle foam will occur especially when the load is heavy.

Once down the trail twenty minutes or so, check and tighten the cinches again. This may seem like a lot of checking, but an ounce of prevention (keeping the saddle in place) is worth a pound of cure (remounting the saddle). Remounting a saddle on the trail can be dangerous to you, the llama, and any traffic that you may encounter.

As you gain experience in how tight the saddle needs to be, you will be able to tighten well enough at the trailhead to avoid most adjustments on the trail.

Loading the Panniers

Your llama's greatest strength is in the front shoulder and close to the backbone. By keeping your pack weight distribution high and forward, you will maximize your llama's comfort and stamina, as well as his center of gravity.

Keep your heaviest items forward, next to the llama's front shoulders and to the inside, close to his ribs.

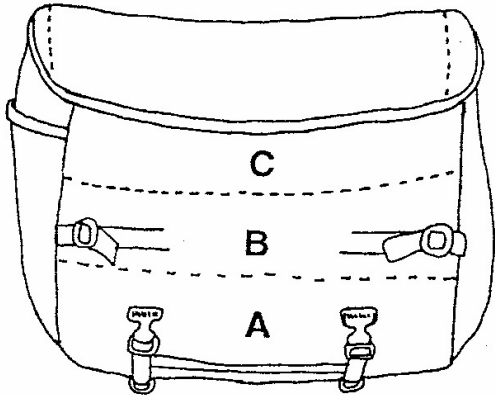

A. Light weights. Soft goods like clothing and sleeping bags

B. Medium to heavy weights, food and gear.

C. Bulky items

Four-gallon square buckets make great storage containers. Two will fit very well into each panner. Position the heaviest one in the front. With the lid snapped on tightly, they serve as varmit-proof containers for food and as camp

seats quite nicely. Remove the metal bails and replace them with nylon webbing handles to prevent undue wear on the panner.

Weigh your panniers using a handheld fish scale that weights up to 50 lbs. They should be within two pounds of each other to prevent the saddle from slipping off center. Start weighing your panniers before you close them up. You can pack your last few items in whichever panner needs the weight for balance. Have a friend hold the scale and panner while you read it or hang the scale from a tree branch, or use a scale that holds the reading while you set the panner down.

Mounting the Panniers on the Saddle

Unbuckle the gray lash straps on the saddle

Load your panniers onto the saddle hooks.

Have a friend load the second panner simultaneously to help keep the saddle in place.

Secure the gray lash straps over the mounting rings

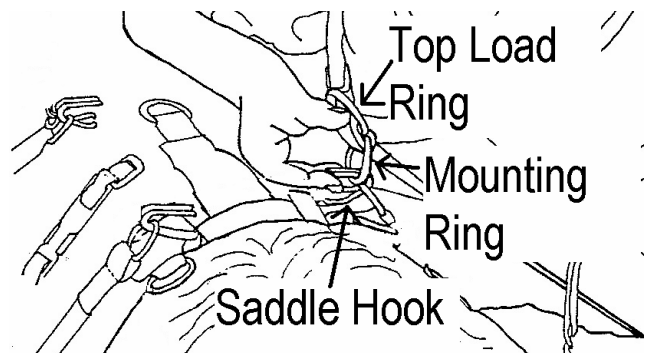

Compressing and Stabilizing the Load

The bottoms of the panniers should not drop below the belly line on the llama.

Use the horizontal and vertical adjustment straps on the panniers to compress the load as much as possible.

Carrying the weight high and narrow will increase your llama's stamina and comfort.

The belly strap is used to stabilize the panniers by pulling them together from the lower handle on each pannier. The tan strap is connected to the alligator clip on the lower front handle of the pannier and placed under the belly to attach to the other pannier in the same fashion. The belly strap should be checked periodically and tightened as compression of the load, saddle, and fiber will cause it to loosen.

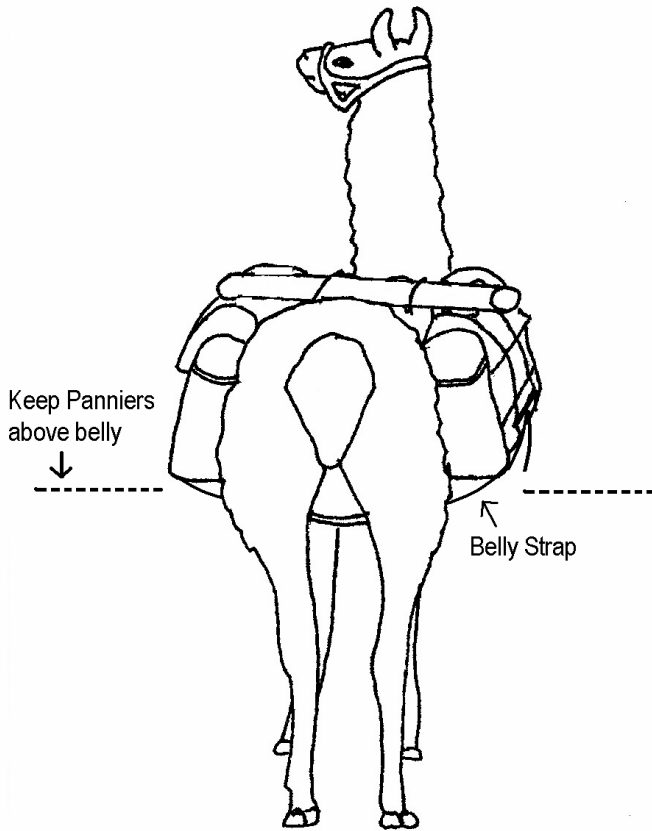

Top Loading

The top load straps are typically yellow and usually arrive attached to the accessory rings either on the saddle or the panniers. Any of the rings can be used depending on the load. The goal is to make the top load a compact, balanced part of the total pack.

Typically, light weight, bulky items are top loaded such as sleeping bags, tents, fishing rod cases, and some camp chairs. As a rule of thumb, the weight of the top load should not exceed 30% of the weight of both panniers in order to keep the load from becoming top heavy. If loaded cross-wise as in the drawing above, the top load should not extend beyond the panniers. If loaded length-wise, make sure the front end isn't going to poke the llama in the neck, or the back end isn't going to extend beyond the back of the llama so as to pose a hazard to trailing llamas or handlers.